

## 1-, 2- and 4-Channel Low Capacitance ESD Protection Arrays

### Features

- 1, 2, and 4 channels of ESD protection
  - Note: For 6 and 8 channel devices, see the CM1213 datasheet.
- Provides ESD protection to IEC61000-4-2 Level 4
  - $\pm 8\text{kV}$  contact discharge
- Low channel input capacitance of 0.85pF typical
- Minimal capacitance change with temperature and voltage
- Channel input capacitance matching of 0.02pF typical is ideal for differential signals
- Zener diode protects supply rail and eliminates the need for external by-pass capacitors
- Each I/O pin can withstand over 1000 ESD strikes\*
- Available in SOT, SC70, and MSOP RoHS-compliant, lead-free packages

### Applications

- USB2.0 ports at 480Mbps in desktop PCs, notebooks and peripherals
- IEEE1394 Firewire® ports at 400Mbps / 800Mbps
- DVI ports, HDMI ports in notebooks, set top boxes, digital TVs, LCD displays
- Serial ATA ports in desktop PCs and hard disk drives
- PCI Express ports
- General purpose high-speed data line ESD protection

### Product Description

The CM1213A family of diode arrays has been designed to provide ESD protection for electronic components or sub-systems requiring minimal capacitive loading. These devices are ideal for protecting systems with high data and clock rates or for circuits requiring low capacitive loading. Each ESD channel consists of a pair of diodes in series which steer the positive or negative ESD current pulse to either the positive ( $V_P$ ) or negative ( $V_N$ ) supply rail. A Zener diode is embedded between  $V_P$  and  $V_N$ , offering two advantages. First, it protects the  $V_{CC}$  rail against ESD strikes, and second, it eliminates the need for a bypass capacitor that would otherwise be needed for absorbing positive ESD strikes to ground. The CM1213A will protect against ESD pulses up to  $\pm 8\text{kV}$  per the IEC 61000-4-2 standard.

These devices are particularly well-suited for protecting systems using high-speed ports such as USB 2.0, IEEE1394 (Firewire®, iLink™), Serial ATA, DVI, HDMI and corresponding ports in removable storage, digital camcorders, DVD-RW drives and other applications where extremely low loading capacitance with ESD protection are required in a small package footprint.

The CM1213A family of devices is available with RoHS-compliant, lead-free finishing.

### Electrical Schematics

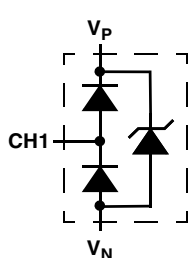

CM1213A-01SO

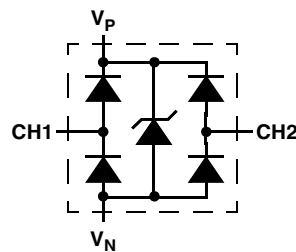
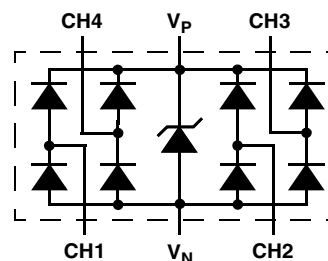
 CM1213A-02SR  
 CM1213A-02SO

 CM1213A-04SO  
 CM1213A-04MR  
 CM1213A-04S7

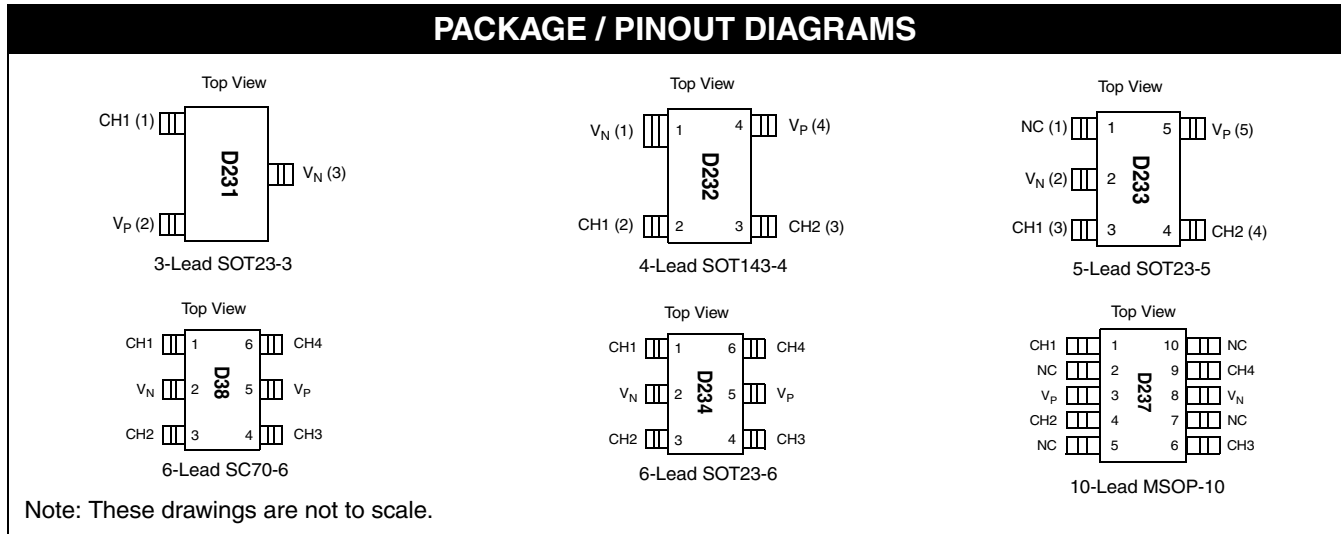
\*Standard test condition is IEC61000-4-2 level 4 test circuit with each pin subjected to  $\pm 8\text{kV}$  contact discharge for 1000 pulses. Discharges are timed at 1 second intervals and all 1000 strikes are completed in one continuous test run. The part is then subjected to standard production test to verify that all of the tested parameters are within spec after the 1000 strikes.

**Package / Pinout Diagrams**

**Pin Descriptions**

1-CHANNEL, 3-LEAD SOT23-3 PACKAGE (CM1213A-01SO)			
PIN	NAME	TYPE	DESCRIPTION
1	CH1	I/O	ESD Channel
2	V <sub>P</sub>	PWR	Positive voltage supply rail
3	V <sub>N</sub>	GND	Negative voltage supply rail

2-CHANNEL, 4-LEAD SOT143-4 PACKAGE (CM1213A-02SR)			
PIN	NAME	TYPE	DESCRIPTION
1	V <sub>N</sub>	GND	Negative voltage supply rail
2	CH1	I/O	ESD Channel
3	CH2	I/O	ESD Channel
4	V <sub>P</sub>	PWR	Positive voltage supply rail

2-CHANNEL, 5-LEAD SOT23-5 PACKAGE (CM1213A-02SO)			
PIN	NAME	TYPE	DESCRIPTION
1	NC		No Connect
2	V <sub>N</sub>	GND	Negative voltage supply rail
3	CH1	I/O	ESD Channel
4	CH2	I/O	ESD Channel
5	V <sub>P</sub>	PWR	Positive voltage supply rail

4-CH, 6-LEAD SOT23-6 (CM1213A-04SO) AND SC70-6 (CM1213A-04S7)			
PIN	NAME	TYPE	DESCRIPTION
1	CH1	I/O	ESD Channel
2	V <sub>N</sub>	GND	Negative voltage supply rail
3	CH2	I/O	ESD Channel
4	CH3	I/O	ESD Channel
5	V <sub>P</sub>	PWR	Positive voltage supply rail
6	CH4	I/O	ESD Channel

4-CHANNEL, 10-LEAD MSOP-10 PACKAGE (CM1213A04MR)			
PIN	NAME	TYPE	DESCRIPTION
1	CH1	I/O	ESD Channel
2	NC		No Connect
3	V <sub>P</sub>	PWR	Positive voltage supply rail
4	CH2	I/O	ESD Channel
5	NC		No Connect
6	CH3	I/O	ESD Channel
7	NC		No Connect
8	V <sub>N</sub>	GND	Negative voltage supply rail
9	CH4	I/O	ESD Channel
10	NC		No Connect

**Ordering Information**

PART NUMBERING INFORMATION				
# of Channels	Leads	Package	Lead-free Finish	
			Ordering Part Number <sup>1</sup>	Part Marking
1	3	SOT23-3	CM1213A-01SO	D231
2	4	SOT143-4	CM1213A-02SR	D232
2	5	SOT23-5	CM1213A-02SO	D233
4	6	SOT23-6	CM1213A-04SO	D234
4	6	SC70-6	CM1213A-04S7	D38
4	10	MSOP-10	CM1213A-04MR	D237

Note 1: Parts are shipped in Tape and Reel form unless otherwise specified.

## Specifications

### ABSOLUTE MAXIMUM RATINGS

PARAMETER	RATING	UNITS
Operating Supply Voltage ( $V_P - V_N$ )	6.0	V
Operating Temperature Range	-40 to +85	°C
Storage Temperature Range	-65 to +150	°C
DC Voltage at any channel input	$(V_N - 0.5)$ to $(V_P + 0.5)$	V

### STANDARD OPERATING CONDITIONS

PARAMETER	RATING	UNITS
Operating Temperature Range	-40 to +85	°C
Package Power Rating SOT23-3, SOT143-4, SOT23-5, SOT23-6, and SC70-6 Packages MSOP-10 Package	225 400	mW mW

### ELECTRICAL OPERATING CHARACTERISTICS (SEE NOTE 1)

SYMBOL	PARAMETER	CONDITIONS	MIN	TYP	MAX	UNITS
$V_P$	Operating Supply Voltage ( $V_P - V_N$ )			3.3	5.5	V
$I_P$	Operating Supply Current	$(V_P - V_N) = 3.3V$			8.0	$\mu A$
$V_F$	Diode Forward Voltage Top Diode Bottom Diode	$I_F = 8mA$ ; $T_A = 25^\circ C$	0.60 0.60	0.80 0.80	0.95 0.95	V V
$I_{LEAK}$	Channel Leakage Current	$T_A = 25^\circ C$ ; $V_P = 5V$ , $V_N = 0V$		$\pm 0.1$	$\pm 1.0$	$\mu A$
$C_{IN}$	Channel Input Capacitance	At 1 MHz, $V_P = 3.3V$ , $V_N = 0V$ , $V_{IN} = 1.65V$ ; Note 2		0.85	1.2	pF
$\Delta C_{IN}$	Channel Input Capacitance Matching	At 1 MHz, $V_P = 3.3V$ , $V_N = 0V$ , $V_{IN} = 1.65V$ ; Note 2		0.02		pF
$V_{ESD}$	ESD Protection - Peak Discharge Voltage at any channel input, in system Contact discharge per IEC 61000-4-2 standard	$T_A = 25^\circ C$ ; Notes 2, 3, and 4	$\pm 8$			kV
$V_{CL}$	Channel Clamp Voltage Positive Transients Negative Transients	$T_A = 25^\circ C$ , $I_{PP} = 1A$ , $t_P = 8/20\mu S$ ; Notes 2 and 4		+10 -1.7		V V
$R_{DYN}$	Dynamic Resistance Positive Transients Negative Transients	$I_{PP} = 1A$ , $t_P = 8/20\mu S$ Any I/O pin to Ground; Notes 2 and 4		0.9 0.5		$\Omega$ $\Omega$

Note 1: All parameters specified at  $T_A = -40^\circ C$  to  $+85^\circ C$  unless otherwise noted.

Note 2: These parameters guaranteed by design and characterization.

Note 3: Standard IEC 61000-4-2 with  $C_{Discharge} = 150pF$ ,  $R_{Discharge} = 330\Omega$ ,  $V_P = 3.3V$ ,  $V_N$  grounded.

Note 4: These measurements performed with no external capacitor on  $V_P$  ( $V_P$  floating).

**Performance Information**

**Input Channel Capacitance Performance Curves**

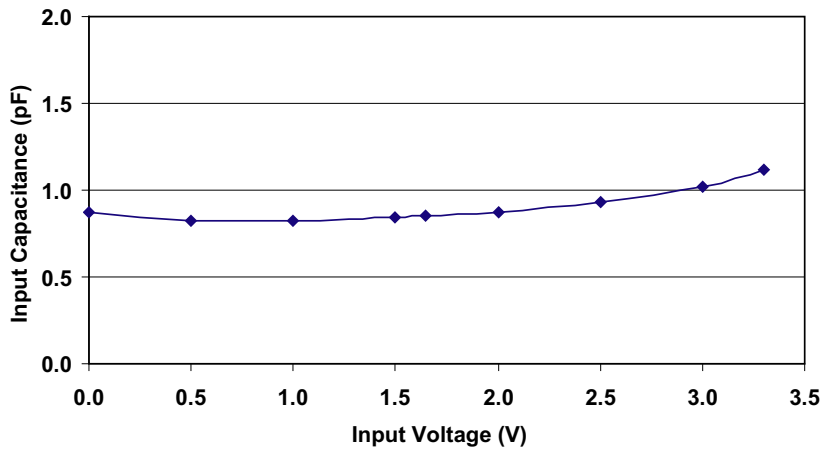

**Typical Variation of  $C_{IN}$  vs.  $V_{IN}$**

( $f=1\text{MHz}$ ,  $V_P = 3.3\text{V}$ ,  $V_N = 0\text{V}$ ,  $0.1 \mu\text{F}$  chip capacitor between  $V_P$  and  $V_N$ ,  $25^\circ\text{C}$ )

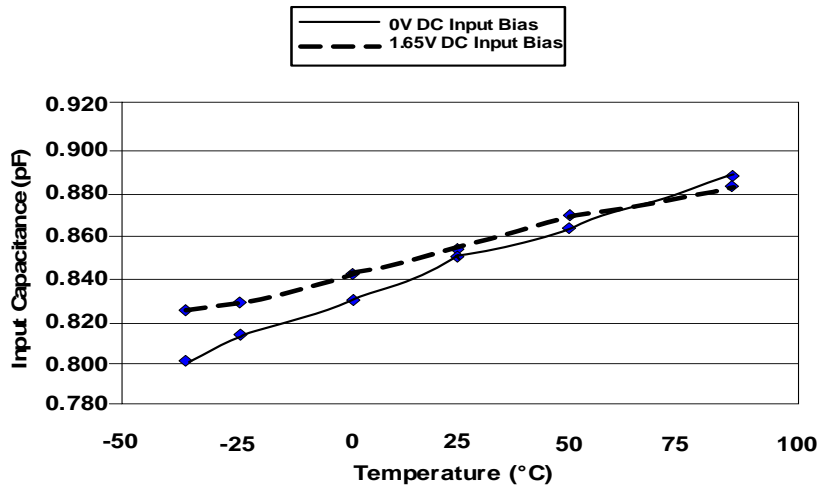

**Typical Variation of  $C_{IN}$  vs. Temp**

( $f=1\text{MHz}$ ,  $V_{IN}=30\text{mV}$ ,  $V_P = 3.3\text{V}$ ,  $V_N = 0\text{V}$ ,  $0.1 \mu\text{F}$  chip capacitor between  $V_P$  and  $V_N$ )

**Performance Information (cont'd)**

Typical Filter Performance (nominal conditions unless specified otherwise, 50 Ohm Environment)

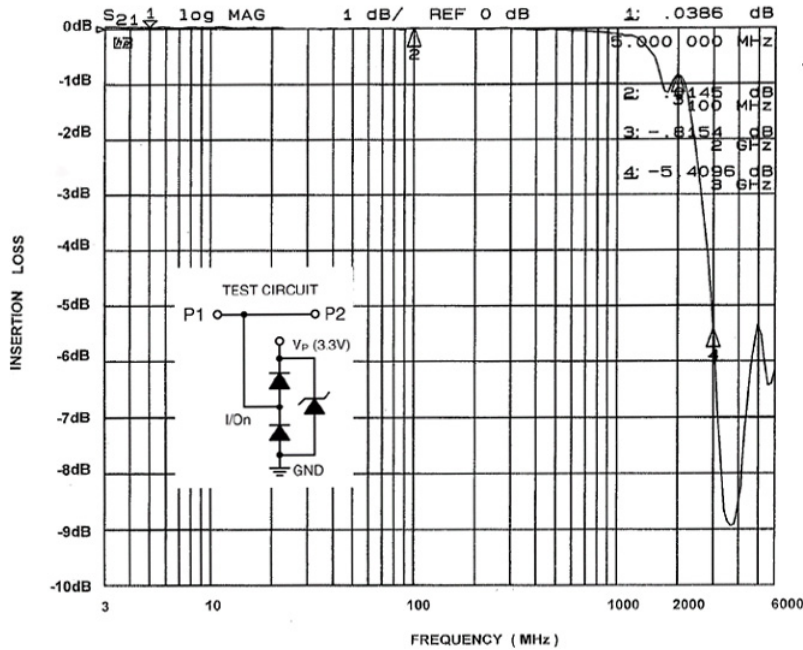

**Figure 1. Insertion Loss (S21) VS. Frequency (0V DC Bias,  $V_p=3.3V$ )**

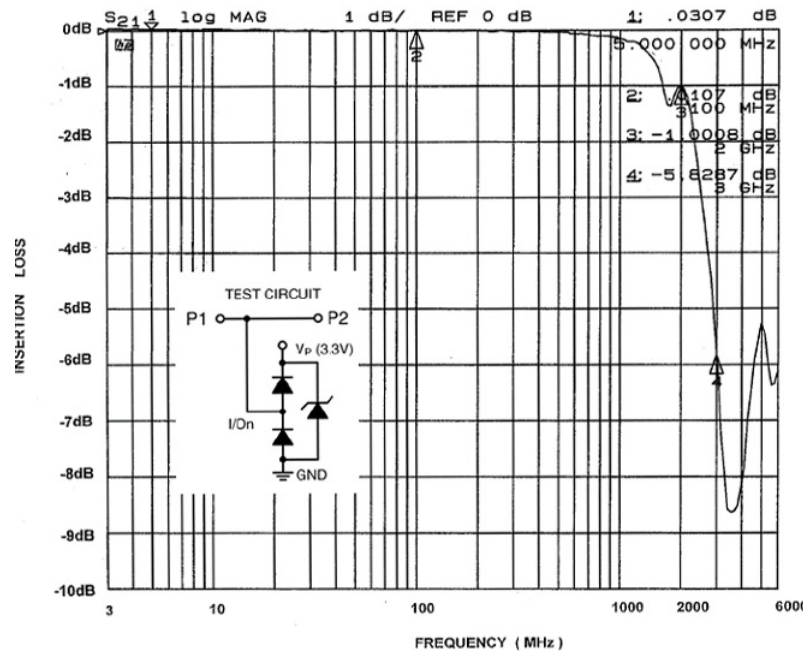

**Figure 2. Insertion Loss (S21) VS. Frequency (2.5V DC Bias,  $V_p=3.3V$ )**

## Application Information

### Design Considerations

In order to realize the maximum protection against ESD pulses, care must be taken in the PCB layout to minimize parasitic series inductances on the Supply/Ground rails as well as the signal trace segment between the signal input (typically a connector) and the ESD protection device. Refer to [Figure 3](#), which illustrates an example of a positive ESD pulse striking an input channel. The parasitic series inductance back to the power supply is represented by  $L_1$  and  $L_2$ . The voltage  $V_{CL}$  on the line being protected is:

$$V_{CL} = \text{Fwd voltage drop of } D_1 + V_{SUPPLY} + L_1 \times d(I_{ESD}) / dt + L_2 \times d(I_{ESD}) / dt$$

where  $I_{ESD}$  is the ESD current pulse, and  $V_{SUPPLY}$  is the positive supply voltage.

An ESD current pulse can rise from zero to its peak value in a very short time. As an example, a level 4 contact discharge per the IEC61000-4-2 standard results in a current pulse that rises from zero to 30 Amps in 1ns. Here  $d(I_{ESD})/dt$  can be approximated by  $\Delta I_{ESD}/\Delta t$ , or  $30/(1 \times 10^{-9})$ . So just 10nH of series inductance ( $L_1$  and  $L_2$  combined) will lead to a 300V increment in  $V_{CL}$ !

Similarly for negative ESD pulses, parasitic series inductance from the  $V_N$  pin to the ground rail will lead to drastically increased negative voltage on the line being protected.

The CM1213A has an integrated Zener diode between  $V_P$  and  $V_N$ . This greatly reduces the effect of supply rail

inductance  $L_2$  on  $V_{CL}$  by clamping  $V_P$  at the breakdown voltage of the Zener diode. However, for the lowest possible  $V_{CL}$ , especially when  $V_P$  is biased at a voltage significantly below the Zener breakdown voltage, it is recommended that a  $0.22\mu\text{F}$  ceramic chip capacitor be connected between  $V_P$  and the ground plane.

As a general rule, the ESD Protection Array should be located as close as possible to the point of entry of expected electrostatic discharges. The power supply bypass capacitor mentioned above should be as close to the  $V_P$  pin of the Protection Array as possible, with minimum PCB trace lengths to the power supply, ground planes and between the signal input and the ESD device to minimize stray series inductance.

### Additional Information

See also California Micro Devices Application Note AP209, "Design Considerations for ESD Protection," in the Applications section at [www.calmicro.com](http://www.calmicro.com).

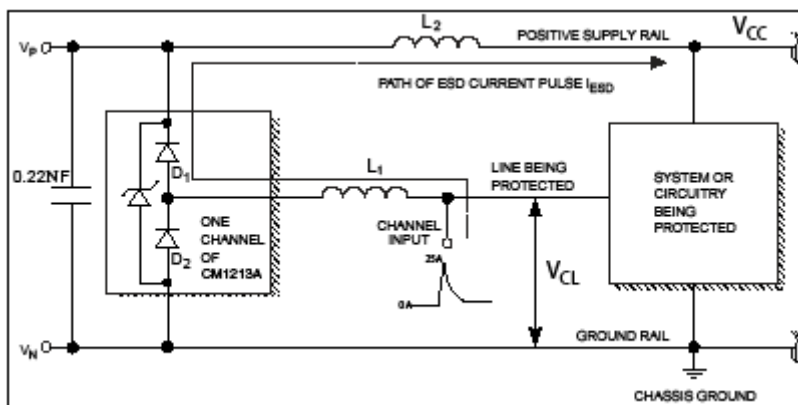

**Figure 3. Application of Positive ESD Pulse Between Input Channel and Ground**

## Mechanical Details

The CM1213A is available in SOT23-3, SOT143-4, and SOT23-5, SOT23-6, SC70-6, and MSOP-10 lead-free packages.

### SOT23-3 Mechanical Specifications, 3 pin

The CM1213A-01SO is supplied in a 3-pin SOT23 package. Dimensions are presented below.

PACKAGE DIMENSIONS				
Package	SOT23-3 (JEDEC name is TO-236)			
JEDEC No.	TO-236 (Var. AB)			
Pins/Leads	3			
Dimensions	Millimeters		Inches	
	Min	Max	Min	Max
A	0.89	1.12	0.0350	0.0441
A1	0.01	0.10	0.0004	0.0039
b	0.30	0.50	0.0118	0.0197
c	0.08	0.20	0.0031	0.0079
D	2.80	3.04	0.1102	0.1197
E	2.10	2.64	0.0827	0.1039
E1	1.20	1.40	0.0472	0.0551
e	0.95 BSC		0.0374 BSC	
e1	1.90 BSC		0.0748 BSC	
L	0.40	0.60	0.0157	0.0236
L1	0.54 REF		0.0213 REF	
# per tape and reel	3000 pieces			
Controlling dimension: millimeters				

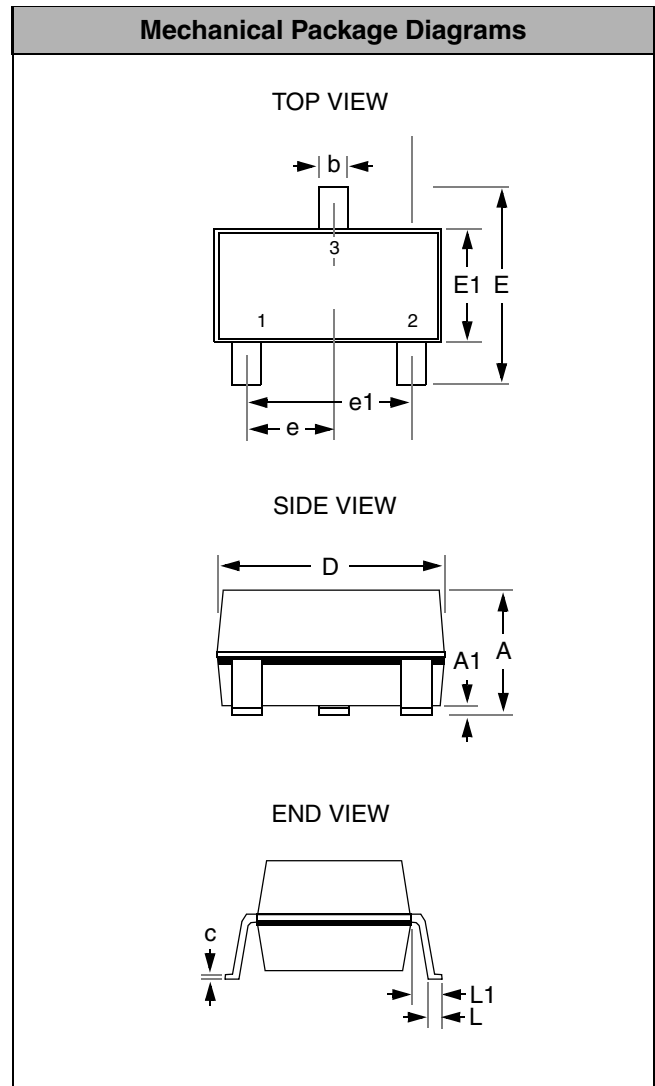

**Package Dimensions for SOT23-3**

## Mechanical Details (cont'd)

### SOT143-4 Mechanical Specifications, 4 pin

The CM1213A-02SR is packaged in a 4-pin SOT143 package. Dimensions are presented below.

PACKAGE DIMENSIONS				
Package	SOT143			
Pins	4			
Dimensions	Millimeters		Inches	
	Min	Max	Min	Max
A	0.80	1.22	0.031	0.048
A1	0.05	0.15	0.002	0.006
b	0.30	0.50	0.012	0.019
b2	0.76	0.89	0.030	0.035
c	0.08	0.20	0.003	0.008
D	2.80	3.04	0.110	0.119
E	2.10	2.64	0.082	0.103
E1	1.20	1.40	0.047	0.055
e	1.92 BSC		0.075 BSC	
e1	0.20 BSC		0.008 BSC	
L	0.4	0.6	0.016	0.024
L1	0.54 REF		0.021 REF	
# per tape and reel	3000 pieces			
Controlling dimension: millimeters				

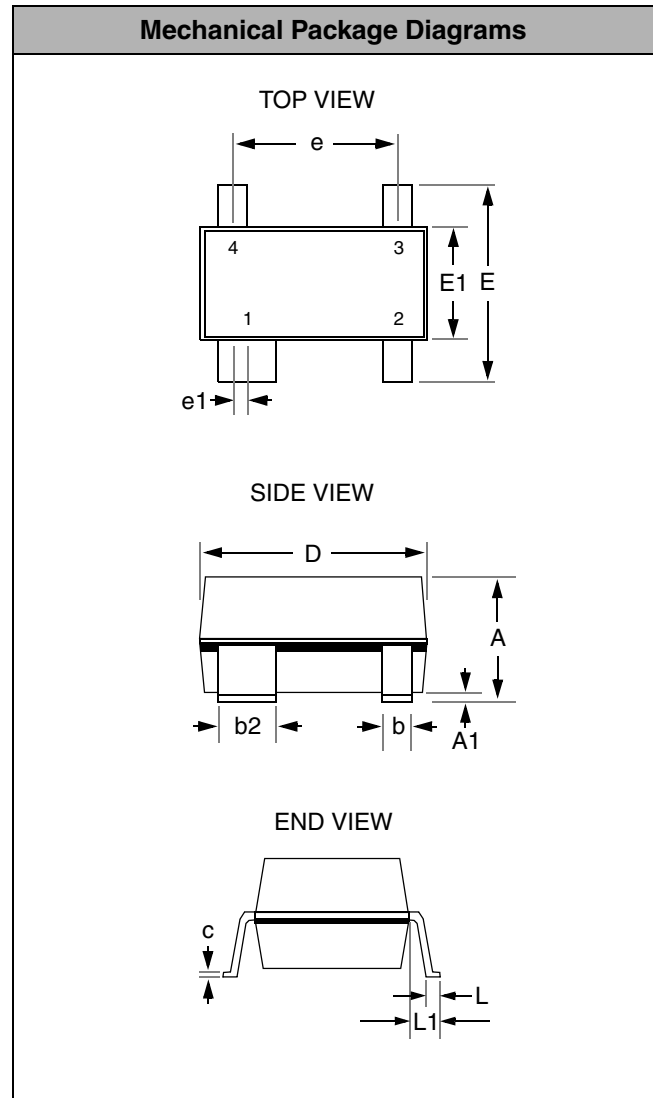

**Package Dimensions for SOT143**

## Mechanical Details (cont'd)

### SOT23-5 Mechanical Specifications, 5 pin

The CM1213A-02SO is supplied in a 5-pin SOT23 package. Dimensions are presented below.

PACKAGE DIMENSIONS				
Package	SOT23-5			
JEDEC No.	MO-178 (Var. AA)			
Pins/Leads	5			
Dimensions	Millimeters		Inches	
	Min	Max	Min	Max
A	--	1.45	--	0.0571
A1	0.00	0.15	0.0000	0.0059
b	0.30	0.50	0.0118	0.0197
c	0.08	0.22	0.0031	0.0087
D	2.75	3.05	0.1083	0.1201
E	2.60	3.00	0.1024	0.1181
E1	1.45	1.75	0.0571	0.0689
e	0.95 BSC		0.0374 BSC	
e1	1.90 BSC		0.0748 BSC	
L	0.30	0.60	0.0118	0.0236
L1	0.60 REF		0.0236 REF	
# per tape and reel	3000 pieces			
Controlling dimensions: millimeters				

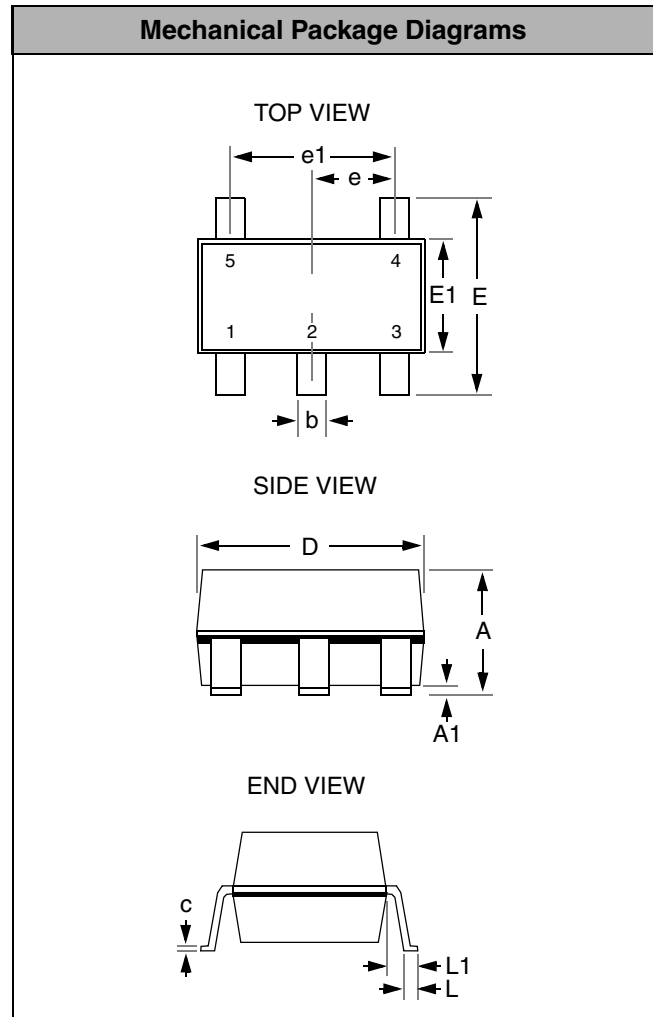

**Package Dimensions for SOT23-5**

## Mechanical Details (cont'd)

### SOT23-6 Mechanical Specifications, 6 pin

The CM1213A-04SO is supplied in a 6-pin SOT23 package. Dimensions are presented below.

PACKAGE DIMENSIONS				
Package	SOT23-6			
JEDEC No.	MO-178 (Var. AB)			
Pins/Leads	6			
Dimensions	Millimeters		Inches	
	Min	Max	Min	Max
A	--	1.45	--	0.0571
A1	0.00	0.15	0.0000	0.0059
b	0.30	0.50	0.0118	0.0197
c	0.08	0.22	0.0031	0.0087
D	2.75	3.05	0.1083	0.1201
E	2.60	3.00	0.1024	0.1181
E1	1.45	1.75	0.0571	0.0689
e	0.95 BSC		0.0374 BSC	
e1	1.90 BSC		0.0748 BSC	
L	0.30	0.60	0.0118	0.0236
L1	0.60 REF		0.0236REF	
# per tape and reel	3000 pieces			
Controlling dimension: millimeters				

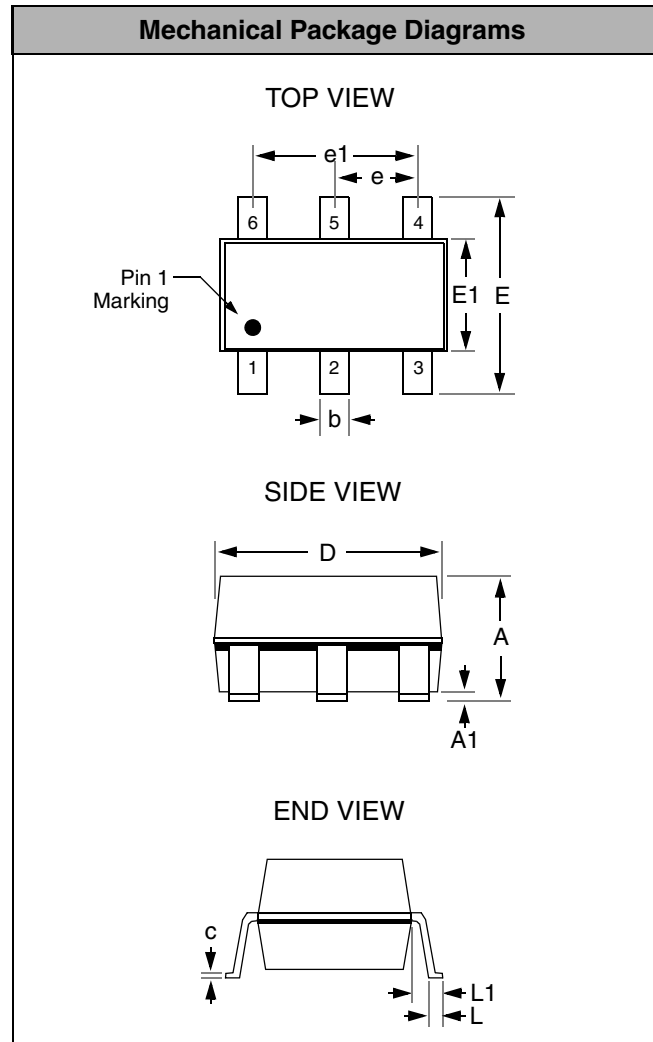

Package Dimensions for SOT23-6

## Mechanical Details (cont'd)

### SC70-6 Mechanical Specifications, 6 pin

The CM1213A-04S7 is supplied in a 6-pin SC70 package. Dimensions are presented below.

PACKAGE DIMENSIONS		
Package	SC70-6 (JEDEC name is MO-203 Issue A)	
Pins	6	
Dimensions	Millimeters	
	Min	Max
A	0.80	1.10
A1	0.00	0.10
A2	0.70	1.00
B	0.15	0.30
c	0.08	0.25
D	1.85	2.25
E	1.15	1.35
e	0.65 BSC	
HE	2.00	2.40
L	0.26	0.46
# per tape and reel	3000 pieces	
Controlling dimension: millimeters		

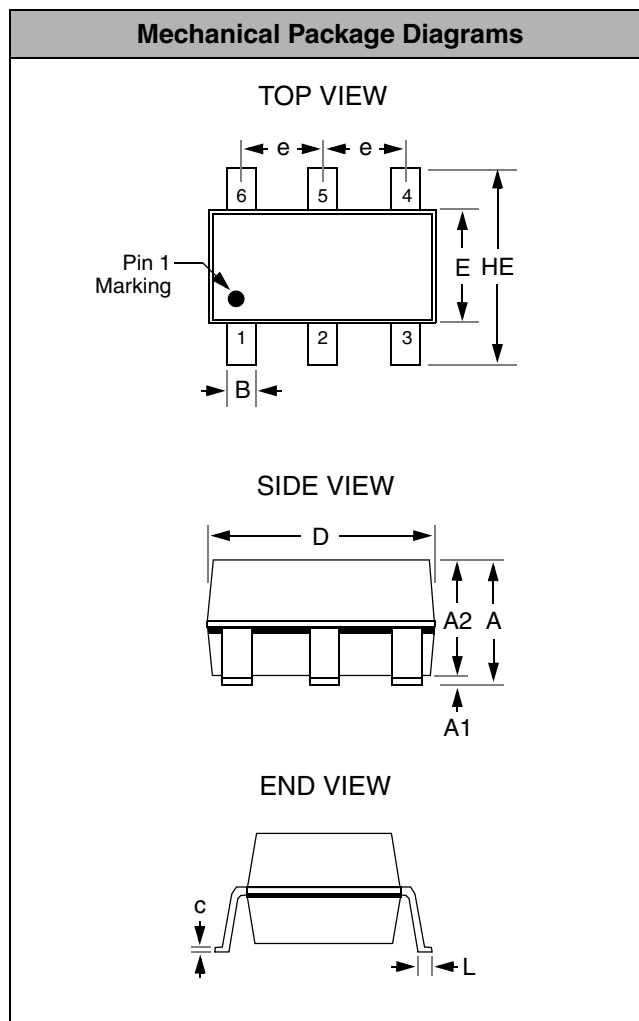

**Package Dimensions for SC70-6**

## Mechanical Details (cont'd)

### MSOP-10 Mechanical Specifications, 10 pin

The CM1213A-04MR is supplied in a 10-lead MSOP package. Dimensions are presented below.

PACKAGE DIMENSIONS				
Package	MSOP			
Pins	10			
Dimensions	Millimeters		Inches	
	Min	Max	Min	Max
A	0.75	0.95	0.028	0.038
A1	0.05	0.15	0.002	0.006
B	0.17	0.27	0.007	0.013
C	0.13	0.23	0.005	0.009
D	2.90	3.10	0.114	0.122
E	2.90	3.10	0.114	0.122
e	0.50 BSC		0.0196 BSC	
H	4.90 BSC		0.193 BSC	
L	0.40	0.70	0.0137	0.029
# per tape and reel	4000			
Controlling dimension: millimeters				

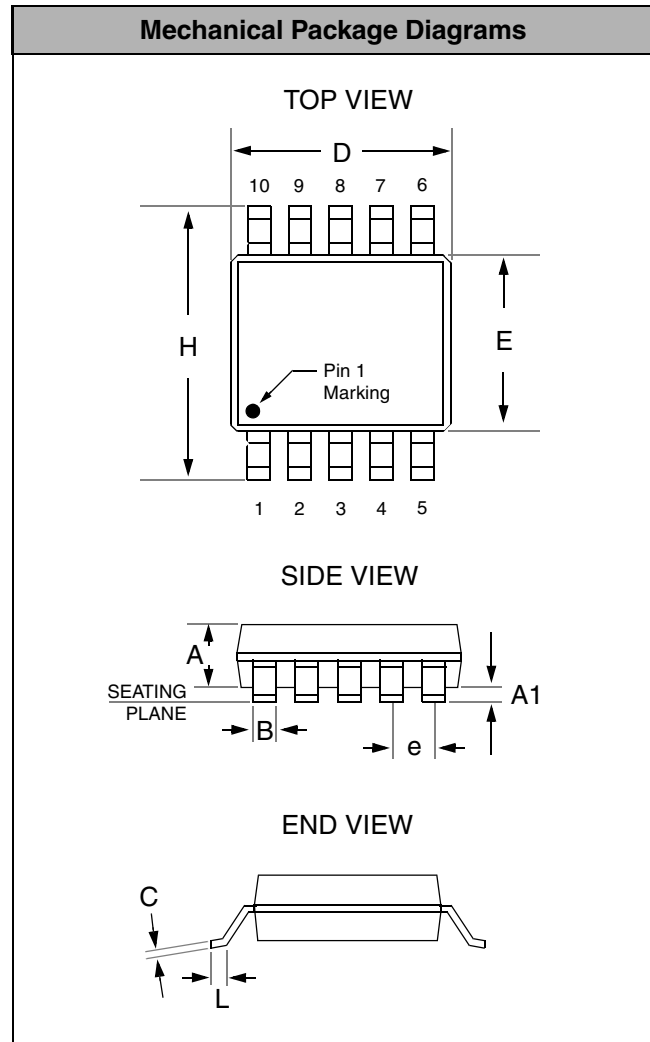

**Package Dimensions for MSOP-10**