

Headset/Speaker EMI Filter Array with ESD Protection

Features

- Functionally and pin compatible with CMD's CSPEMI201A and CM1411
- *OptiGuard*[™] coated for improved reliability at assembly
- Two channels of EMI filtering for 8Ω speakers
- Pi-style EMI filters in a capacitor-resistor-capacitor (C-R-C) network
- Greater than 30dB attenuation at 1GHz
- ±30kV ESD protection on each channel per IEC 61000-4-2 Level 4, contact discharge
- Extremely low lead inductance for optimum filter and ESD performance
- 5-bump, 0.96mm X 1.33mm footprint Chip Scale Package (CSP)
- Lead-free finishing

Applications

- Headset Speaker port in mobile handsets
- I/O port protection for mobile handsets, notebook computers, PDAs etc.
- EMI filtering for data ports in cell phones, PDAs or notebook computers.

Product Description

CMD's CM1416 is an EMI filter array with ESD protection, which integrates two Pi-filters (C-R-C). The CM1416 has component values of 117pF-2Ω-117pF. The parts include avalanche-type ESD diodes on every pin, which provide a very high level of protection for sensitive electronic components that may be subjected to electrostatic discharge (ESD). The ESD diodes safely dissipate ESD strikes of ±30kV, exceeding the maximum requirement of the IEC 61000-4-2 international standard. Using the MIL-STD-883 (Method 3015) specification for Human Body Model (HBM) ESD, these devices protect for contact discharges at greater than ±30kV.

This device is well suited for portable electronics (e.g. mobile handsets, PDAs, notebook computers) because of its small package and easy-to-use pin assignments. In particular, the CM1416 is ideal for filtering unwanted EMI-induced noise and providing ESD protection for headset speaker port applications in wireless handsets with 8Ω speakers.

The CM1416 incorporates *OptiGuard*[™] coating which results in improved reliability at assembly. The CM1416 is available in a space saving, low profile Chip Scale Package with lead-free finishing.

Electrical Schematic

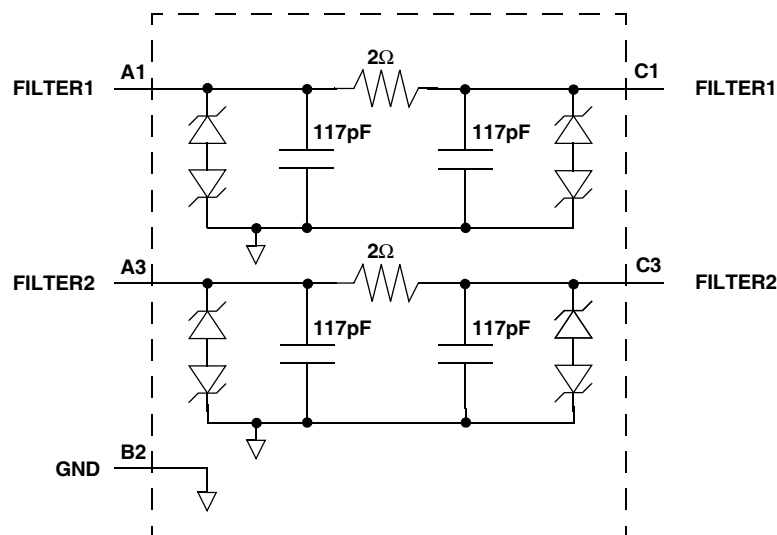

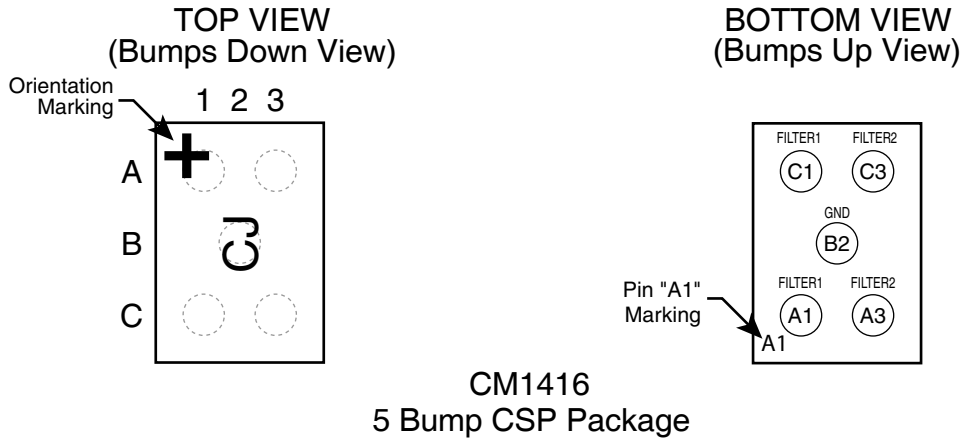
PACKAGE / PINOUT DIAGRAMS

Notes:

1) These drawings are not to scale.

PIN DESCRIPTIONS

PIN	NAME	DESCRIPTION
A1	FILTER1	EMI Filter 1
A3	FILTER2	EMI Filter 2
B2	GND	Device Ground
C1	FILTER1	EMI Filter 1
C3	FILTER2	EMI Filter 2

Ordering Information
PART NUMBERING INFORMATION

Pins	Package	Lead-free Finish	
		Ordering Part Number ¹	Part Marking
5	CSP	CM1416-03CP	CJ

Note 1: Parts are shipped in Tape & Reel form unless otherwise specified.

Specifications

ABSOLUTE MAXIMUM RATINGS

PARAMETER	RATING	UNITS
Storage Temperature Range	-65 to +150	°C
DC Power per Resistor (note 5)	100	mW
DC Package Power Rating (note 5)	500	mW

STANDARD OPERATING CONDITIONS

PARAMETER	RATING	UNITS
Operating Temperature Range	-40 to +85	°C

ELECTRICAL OPERATING CHARACTERISTICS (SEE NOTE 1)

SYMBOL	PARAMETER	CONDITIONS	MIN	TYP	MAX	UNITS
R	R1 Resistance			2		Ω
C _{TOT}	Total Channel Capacitance	At 2.5VDC, 1MHz, 30mVAC, Note 3	187	234	281	pF
C ₁	C1 Capacitance	At 2.5VDC, 1MHz, 30mVAC, Note 3	93	117	140	pF
V _{DIODE}	Diode Standoff Voltage	I _{DIODE} = 10μA		6.0		V
I _{LEAK}	Diode Leakage Current	V _{IN} =±3.3V (reverse bias voltage)		0.1	2	μA
V _{SIG}	Signal Clamp Voltage Positive Clamp Negative Clamp	I _{LOAD} = 10mA I _{LOAD} = -10mA	6.4 -9.8	7.6 -7.6	9.8 -6.4	V V
V _{ESD}	In-system ESD Withstand Voltage a) Human Body Model, MIL-STD-883, Method 3015 b) Contact Discharge per IEC 61000-4-2 Level 4	Notes 2 and 3	±30 ±30			kV kV
R _{DYN}	Dynamic Resistance Positive Negative			0.95 0.90		Ω Ω
f _C	Cut-off frequency Z _{SOURCE} = 50Ω, Z _{LOAD} = 50Ω	R = 2Ω, C = 117pF		21		MHz

Note 1: T_A=25°C unless otherwise specified.

Note 2: ESD applied to input and output pins with respect to GND, one at a time.

Note 3: These parameters are guaranteed by design and characterization.

Performance Information

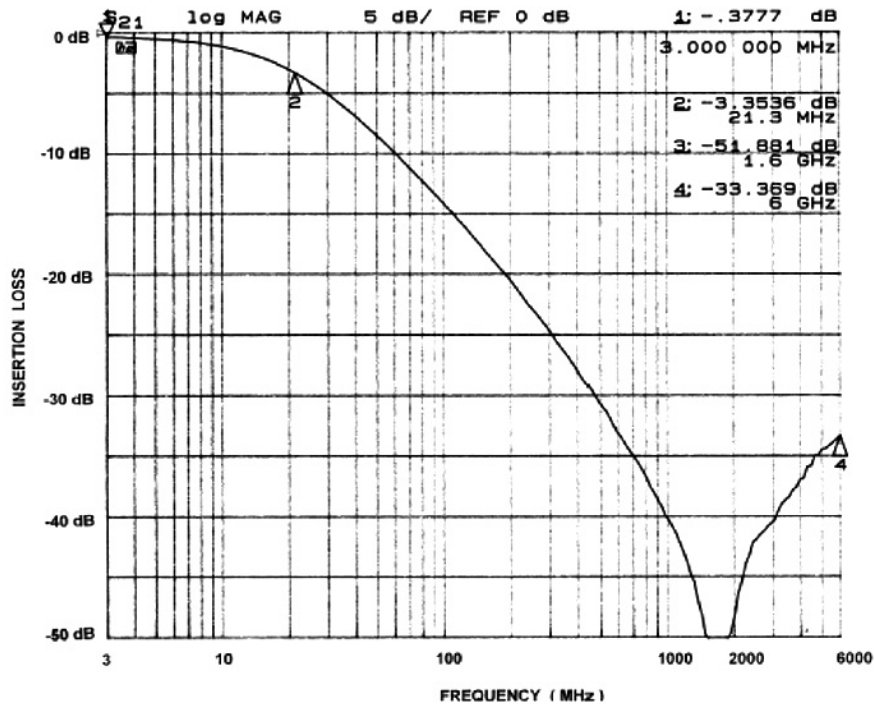

Figure 1. Typical EMI Filter Performance (0VDC, 50 Ohm Environment)

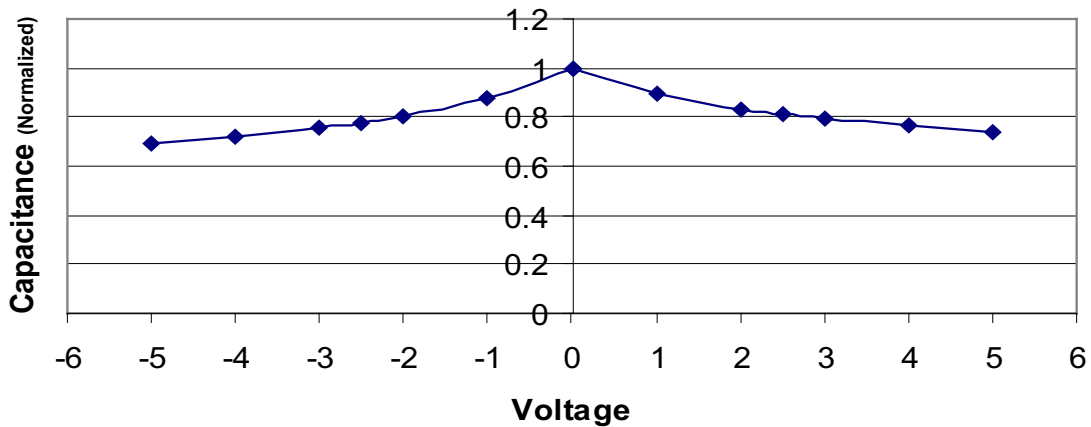

Figure 2. Typical Diode Capacitance VS. Input Voltage (normalized to 2.5VDC)

Application Information

Refer to Application Note AP-217, "The Chip Scale Package", for a detailed description of Chip Scale Packages offered by California Micro Devices.

PRINTED CIRCUIT BOARD RECOMMENDATIONS	
PARAMETER	VALUE
Pad Size on PCB	0.275mm
Pad Shape	Round
Pad Definition	Non-Solder Mask defined pads
Solder Mask Opening	0.325mm Round
Solder Stencil Thickness	0.125 - 0.150mm
Solder Stencil Aperture Opening (laser cut, 5% tapered walls)	0.330mm Round
Solder Flux Ratio	50/50 by volume
Solder Paste Type	No Clean
Pad Protective Finish	OSP (Entek Cu Plus 106A)
Tolerance — Edge To Corner Ball	±50µm
Solder Ball Side Coplanarity	±20µm
Maximum Dwell Time Above Liquidous	60 seconds
Maximum Soldering Temperature for Lead-free Devices Using Lead-free Solder Paste	260°C

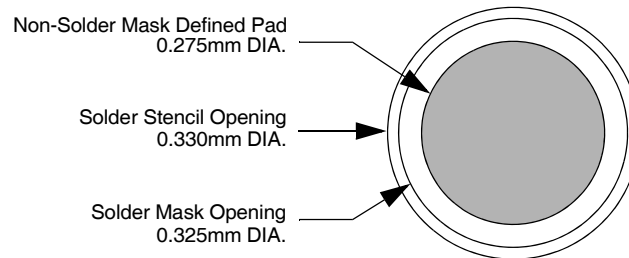

Figure 3. Recommended Non-Solder Mask Defined Pad Illustration

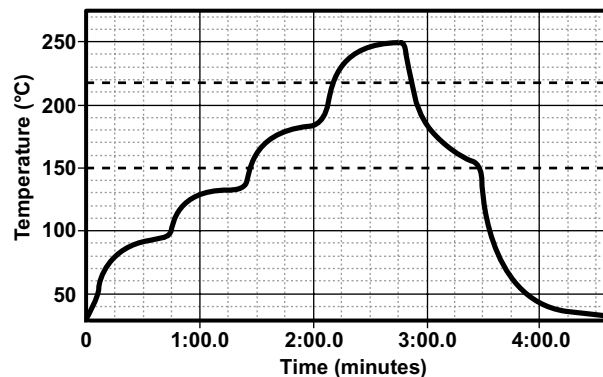

Figure 4. Lead-free (SnAgCu) Solder Ball Reflow Profile

Mechanical Details

CSP Mechanical Specifications

The CM1416 is supplied in a custom Chip Scale Package (CSP). Dimensions are presented below. For complete information on CSP packaging, see the California Micro Devices CSP Package Information document.

PACKAGE DIMENSIONS						
Package	Custom CSP					
Bumps	5					
Dim	Millimeters			Inches		
	Min	Nom	Max	Min	Nom	Max
A1	0.955	1.000	1.045	0.0376	0.0394	0.0411
A2	1.325	1.370	1.415	0.0522	0.0539	0.0557
B1	0.495	0.500	0.505	0.0195	0.0197	0.0199
B2	0.245	0.250	0.255	0.0096	0.0098	0.0100
B3	0.430	0.435	0.440	0.0169	0.0171	0.0173
B4	0.430	0.435	0.440	0.0169	0.0171	0.0173
C1	0.200	0.250	0.300	0.0079	0.0098	0.0118
C2	0.200	0.250	0.300	0.0079	0.0098	0.0118
D1	0.575	0.644	0.714	0.0226	0.0254	0.0281
D2	0.368	0.419	0.470	0.0145	0.0165	0.0185
# per tape and reel	3500 pieces					
Controlling dimension: millimeters						

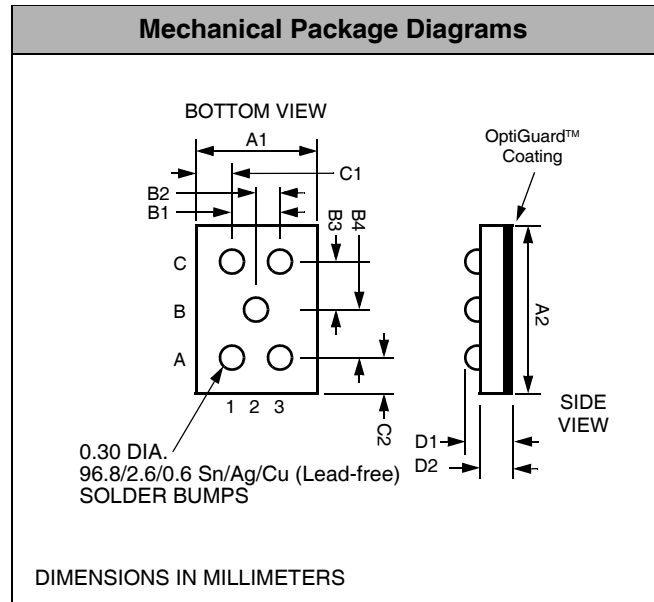

Package Dimensions for CM1416 Chip Scale Package

CSP Tape and Reel Specifications

PART NUMBER	CHIP SIZE (mm)	POCKET SIZE (mm) B ₀ X A ₀ X K ₀	TAPE WIDTH W	REEL DIAMETER	QTY PER REEL	P ₀	P ₁
CM1416	1.33 x 0.96 x 0.644	1.42 x 1.07 x 0.74	8mm	178mm (7")	3500	4mm	4mm

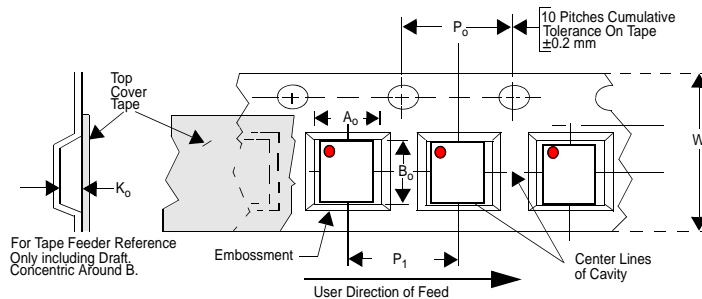

Figure 5. Tape and Reel Mechanical Data